

FORM AND FUNCTION

- Sleek, low profile housing
- Dark Sky Compliant, Full Cutoff
- Engineered for optimum thermal management
- Low depreciation rate : L70 = 483,000 Hours
- Reduces energy consumption and costs up to 65%
- Exceeds IES foot candle levels utilizing the least number of poles and fixtures per project
- Optical system designed specifically for Tennis Courts

CONSTRUCTION

- Aluminum
- External cooling fins
- Corrosion resistant external hardware, Stainless Steel

FINISH

- 3-5 mils electrostatic powder coat.
- NLS' standard high-quality finishes prevent corrosion protects against and extreme environmental conditions

WARRANTY

Five-year limited warranty for drivers and LEDs.

LISTINGS

- Certified to UL 1598
- UL 8750
- CSA C22.2 No. 250.0
- DesignLights Consortium® (DLC)

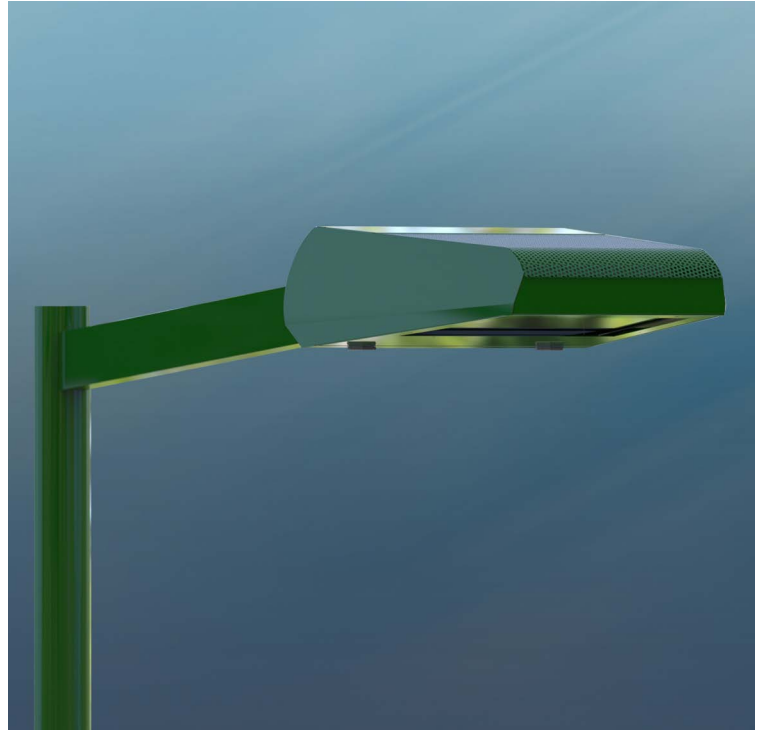

LED WATTAGE CHART

	96L	112L	128L	144L	160L	176L	192L
1050 milliamps	316w	366w	409w	458w	505w	551w	594w

SIZE 2



SIZE 3

Project Name:

Type:

Cat #	Light Dist.	No. of LEDs	Milliamps	Kelvin	Volts	Mounting	Color	Shields	Options
VUE-2 (316W Max) (VUE-2)	Tennis Optic (TT)	Size 2		1050 (1)	4000K (40K)	120-277 (UNV)	Black (BLK)	House Side Shield <i>*Mounted on Back</i> (HSS)	Bird Spikes (BS) Marine Grade Finish (MGF)
		80 (80L) 96 (96L)							
VUE-3 (594W Max) (VUE-3)		Size 3		5000K (50K)	347-480 (HV)	Davit Arm (DA) Knuckle Mount (KM)	Green (GRN) Custom (CS)	Front Side Shield (FSS) 4 Sided Shield (4SS)	Photocell (PC) <i>*Universal Voltage 120-277</i> Photocell + Receptacle (PCR) Receptacle + Shorting Cap (PER) Motion Sensor (MS) Surge Protector (10K) Low Iron Lens (LIL) 10G 3-Wire SO Chord 26' Pigtail (SO26)
		112 (112L)							
		128 (128L)							
		144 (144L)							
		160 (160L)							
		176 (176L) 192 (192L)							

PRODUCT SPECIFICATIONS

Housing: Aluminum
LED: Lumileds Luxeon MX. CRI 70
Optics: Star Power Type Tennis (TT)
Watts: 316-594
L70 Depreciation: 483,000 Hours (@ 77°F/25°C)
Listings: UL 1598 Listed , DLC QPL 

Driver: 0-10V Dimming driver as standard by Philips Advance
 THD @ Max Load < 15%
 Power Factor @ Max Load < 0.95
Kelvin: 4000, or 5000
Finish: 5 mils Powder Coat
Warranty: Standard Warranty is 5 years for Driver and LEDs

PRODUCT DIMENSIONS

VUE - LUMEN DATA CHART													
PART NUMBER	TT OPTIC	Lm/W	*DLC	TT-HSS OPTIC	Lm/W	*DLC	TT-FSS OPTIC	Lm/W	*DLC	TT-4SS OPTIC	Lm/W	*DLC	WATT
VUE-2-96L-1-40K	32232	102	S	31284	99	S	32864	104	S	32548	103	S	316
VUE-2-96L-1-50K	33180	105	S	32232	102	S	34444	109	S	34128	108	S	316
VUE-3-112L-1-40K	37332	102	S	36234	99	S	38064	104	S	37698	103	S	366
VUE-3-112L-1-50K	38430	105	S	37332	102	S	39894	109	S	39528	108	S	366
VUE-3-128L-1-40K	41718	102	S	40491	99	S	42536	104	S	42127	103	S	409
VUE-3-128L-1-50K	42945	105	S	41718	102	S	44581	109	S	44172	108	S	409
VUE-3-144L-1-40K	46716	102	S	45342	99	S	47632	104	S	47174	103	S	458
VUE-3-144L-1-50K	48090	105	S	46716	102	S	49922	109	S	49464	108	S	458
VUE-3-160L-1-40K	51510	102	S	49995	99	S	52520	104	S	52015	103	S	505
VUE-3-160L-1-50K	53025	105	S	51510	102	S	55045	109	S	54540	108	S	505
VUE-3-176L-1-40K	56202	102	S	54549	99	S	57304	104	S	56753	103	S	551
VUE-3-176L-1-50K	57855	105	S	56202	102	S	60059	109	S	59508	108	S	551
VUE-3-192L-1-40K	60588	102	S	58806	99	S	61776	104	S	61182	103	S	594
VUE-3-192L-1-50K	62370	105	S	60588	102	S	64746	109	S	64152	108	S	594

*DLC S= Standard 

DIMENSION	VUE-2	VUE-3
A	21.56 in	26.17 in
B	8.00 in	8.36 in
C	27.06 in	32.94 in
Weight	34 lbs.	62 lbs.

EPA	VUE-2	VUE-3
Single	1.16	1.43
Double	2.32	2.86
Triple	2.5	4.78
Quad	3.6	4.88

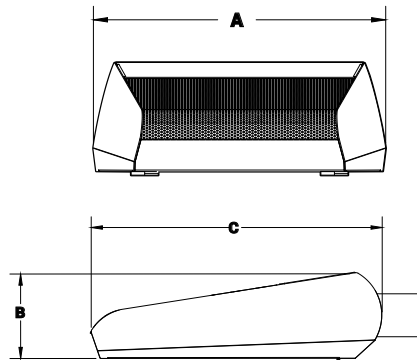

SHIELD OPTIONS

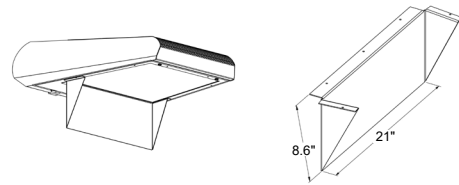

HOUSE SIDE SHIELD (HSS)



FRONT SIDE SHIELD (FSS)

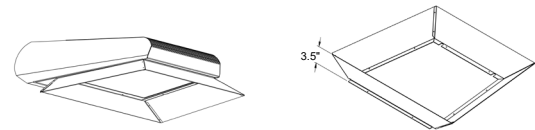

FOUR SIDE SHIELD (4SS)



DesignLights Consortium (DLC) qualified Product. Some configurations of this product family may not be DesignLights Consortium (DLC) listed, please refer to the DLC qualified products list to confirm listed configurations. <http://www.designlights.org>



701 Kingshill Place, Carson, CA 90746
 Call Us Today 310-341-2037

nslighting.com